

MV Load Switch

FZN25/FZRN25-12 Indoor Vacuum Load Switch

- FZN25, FZRN25 vacuum load switch and composite apparatus, suitable for three-phase AC 50Hz ring network or terminal power supply and industrial electrical equipment, for load control and short circuit protection use, load switch open and close the closed loop current, no-load transformer and cable charging current, composite apparatus can break any current till rated short circuit current.
- Adopt the straight move or isolating fracture and vacuum interrupter linkage. With function of manual and electric operation.
- FZN25, FZRN25 special transmission structure design, arc extinguish chamber only withstand voltage in the moment of closing and breaking, small size, low price.
- FZN25, FZRN25 can realize isolation fracture and arc extinguish chamber fracture disposable operating.
- FZN25, FZRN25 has a grounding switch mutual linkage grounding valve between the static contact and movable conductive cylinder, ensures safety and convenient maintenance.
- Standard: IEC 60265-1, IEC 62271-105.

General

MV Load Switch

FZN25/FZRN25-12 Indoor Vacuum Load Switch

Selection

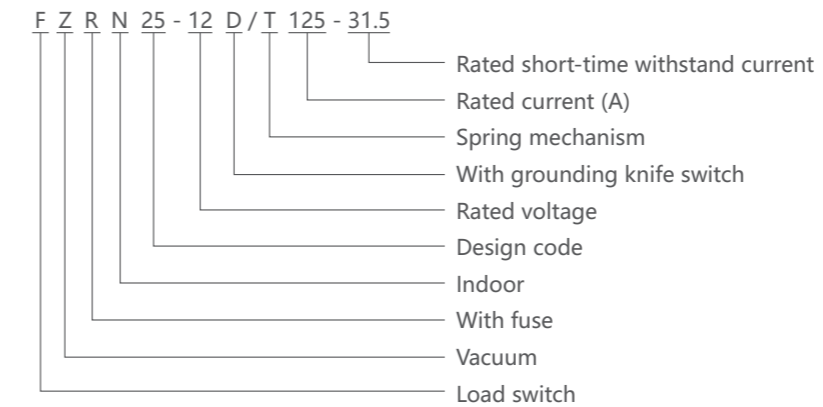
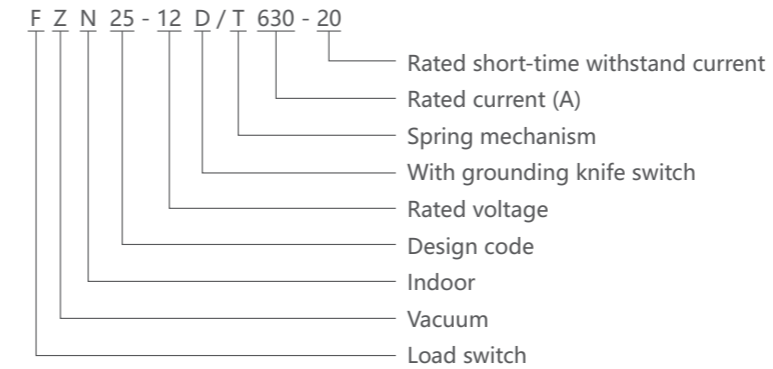

Operating Conditions

- Ambient air temperature: upper limit +40°C, lower limit -25°C (allow storage at -30°C), 24h average value is not higher than +35°C;
- Altitude: no more than 1000m;
- Relative humidity: daily average value is not greater than 95%, monthly average is not greater than 90%;
- Earthquake intensity: do not exceed 8 degree;
- The surrounding air is not corrosive and flammable gas, steam and other significant pollution;
- No regular violent vibration;
- Contamination grade: II class;

MV Load Switch

FZN25/FZRN25-12 Indoor Vacuum Load Switch

Technical data

Item	Unit	FZN25-12D/ T630-20	FZRN25-12D/ T125-20
Voltage, current parameters			
Rated voltage	kV	12	
Rated frequency	Hz	50	
Rated current	A	630	125
Rated short time power frequency withstand voltage (1min)	kV	Interrupter fracture 30; phase to earth 42; isolation fracture 48	
Rated lightning impulse withstand voltage (peak)	kV	Phase to earth 75; isolation fracture 85	
Rated peak withstand current	kA	50	-
4s rated short-time withstand current	kA	20	-
Rated active load breaking current	A	630	-
Rated loop breaking current	A	630	-
Rated cable charging breaking current	A	10	-
Interrupting no load transformer capacity	kVA	1250	-
Rated short-circuit breaking current	kA	-	31.5
Rated transfer current, rated AC current	A	-	2000
Fuse type			SDLAJ-12 SFLAJ-12
The impactor energy output	J		2-5 (medium)
Rated short-circuit closing current	kA	50	
Grounding switch rated stability current	kA	50	
Grounding switch 2S thermal stability current	kA	20	
The auxiliary circuit rated voltage	V	≈220/110	
Mechanical life	Times	10000	

MV Load Switch

FZN25/FZRN25-12 Indoor Vacuum Load Switch

Outline and mounting dimensions

