

YCQ4-100E/R PC type

Automatic transfer switch

OPERATION INSTRUCTION

Standard: IEC 60947-6-1

CNC

Deliver
Power For Better Life

-  Before installing and using this product, please read this manual carefully and pay more attention to safety.

1 General

The dual power automatic switch is a newly developed miniature household power switch, which is mainly used to test whether the main power supply or stand by power supply is normal. When the normal power supply is abnormal, the standby power supply starts to work immediately, which ensures the continuity, reliability and safety of power supply, This product is specially designed for household rail installation and is specially used for Pz30distribution box. The dual power automatic switch is suitable for emergency power supply systems with 50 or 60 Hz and rated 400V AC. ATS has the characteristics of solid structure, reliable conversion, convenient installation and maintenance and long service life. It is widely used in various occasions where power failure can not be sustained, and can be operated by electricity or manually. ATS is composed of TSE and controller. Standard: IEC 60947-6-1

2 Operating conditions

2.1 Ambient air temperature

The maximum temperature shall not exceed 40°C the minimum temperature shall not be lower than-5°C, and the average temperature within 24 hours shall not be

higher than 35°C.

2.2 Altitude

The altitude of the installation site should not be higher than 2000m.

2.3 Atmospheric conditions

When the maximum temperature reaches 40°C, the relative humidity of the installation site should not exceed 50%; when the temperature is the minimum temperature -5°C, the relative humidity is higher, for example, the temperature is 25°C, and the relative humidity is 90%. Due to the temperature change, special measures should be taken to deal with the occasional condensation on the surface of the product.

2.4 Pollution grade

The pollution grade of ATS conforms to grade 3 specified in IEC 60947-6-1.

2.5 Installation category

The installation type of ATS conforms to the category specified in IEC 60947-6-1

2.6 Installation conditions

ATS can be installed vertically in control cabinet or distribution cabinet. Make sure the installation distance meets the requirements in Figure 8.

3 Type designation

3.1 Model and meaning

YC Q4 - 100 □

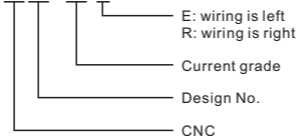

4 Technical data

Specification	100A		
Rated current I_e (A)	16,20,25,32,40,50,63,80,100		
Insulation voltage U_i	AC690V,50Hz		
Rated voltage U_e	AC400V,50Hz		
Classification	PC class: can be manufactured and withstood without short circuit current.		
Utilization category	AC-33iB	AC-31B	
Pole No.	2P	3P	4P
Weight(kg)	1.7	2.1	2.6
Electrical	Life: 2000 times; Manual operation: 5000 times		
Rated short circuit current I_q	50kA		
Short circuit protection device (fuse)	RT16-00-63A		

Rated impulse withstand voltage	8kV
Control circuit	Rated control voltage U_s : AC220V/50Hz Normal working conditions: 85-110% U_s
Auxiliary circuit	2 relays, each with two sets of contact converter contact capacity: AC220V/50Hz $I_e=5y$
Conversion time of contactor	<50ms
Operation conversion time	<50ms
Return conversion time	<50ms
Power off time	<50ms

5 Wiring diagram

Fig.1

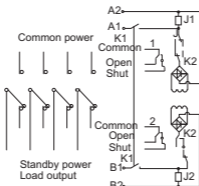

K1:manual/automatic selector switch K2,

K3:internal valve position switch

J1:common 220V A power relay

J2:standby 220V B power relay

1:passive signal output of A power supply

2:passive signal output of B power supply

6 Controller

Wiring diagram of YCQ4E

Fig.2

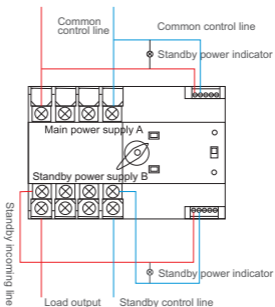

100/2P wiring diagram of YCQ4E

Fig.3

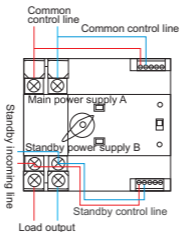

100/3P wiring diagram of YCQ4E

Fig.4

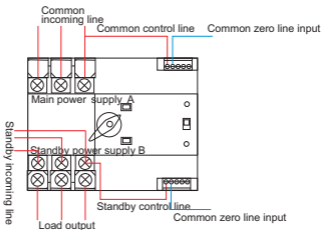

100/4P wiring diagram of YCQ4E

Fig.5

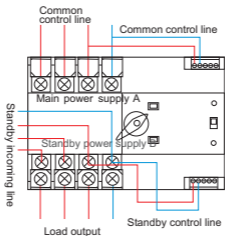

Timing switching connection mode of YCQ4E

Fig.6

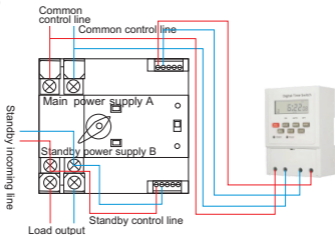

Special connection mode of photovoltaic inverter of YCQ4E

Fig.7

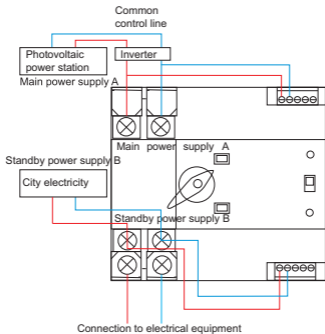

Overall and mounting dimension of YCQ4E

Fig.8

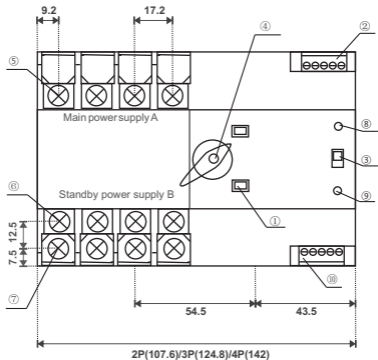

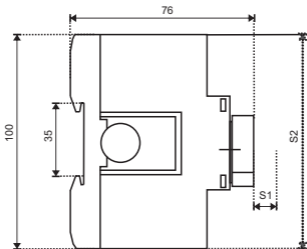

Safe distance: S1: $\geq 30\text{mm}$ S2: $\geq 203\text{mm}$

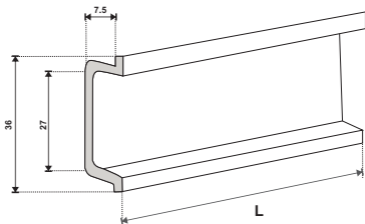

- ① Status position indication
- ② Main power terminal and passive signal(AC220V)
- ③ Manual/automatic switch
- ④ Manual handle
- ⑤ Main terminal of common power side
- ⑥ Main terminal of standby power side
- ⑦ Main terminal of load connection side
- ⑧ A power indicator
- ⑨ B power indicator
- ⑩ Standby power terminal and passive signal AC220V

7 Installation and wiring

7.1 Ensure that professionals read this manual before installation and wiring.

7.2 Please check the integrity of ATS before installation, then open and close ATS with the operating handle, check the flexibility of transmission device and detect the load generation and disconnection conditions of common and standby power supplies at each stage.

7.3 See the figure for the correct installation steps. The trademark is in front of the product. If the installation can not be carried out according to the correct procedures due to wiring and other reasons, please contact us. The safe distances S1,S2 should not be lower than the labels in Fig.8.(See figure below for details)

7.4 Detection control voltage: 50Hz,AC220V.The coil in the control circuit can not be too long. The cross-sectional area of copper wire should not be greater than2.0mm .

7.5 According to the installation requirements of power distribution system, please provide appropriate circuit breakers to ensure the safety of staff and equipment.

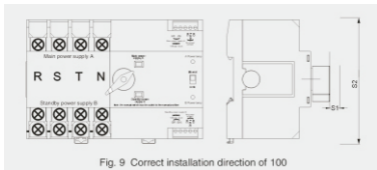

Fig. 9 Correct installation direction of 100

8 Maintenance, inspection and storage

8.1 Maintenance and inspection shall be operated by professionals and all power supplies shall be cut off in advance.

8.2 In order to ensure the good performance of ATS, the first maintenance and inspection shall be carried out within 6 months after use, and shall be maintained and inspected at least once a year. In harsh installation conditions, the frequency of maintenance and inspection should be increased.

8.3 Maintenance and Inspection Items

- Please remove dust and dirt in case of failure.
- Please check whether the contact parts of the electrical contacts are deformed and damaged, and remove bunt metal particles attached to and

around the surface.

c. Rust, acidification and dust on the contact surface may lead to poor contact. Please operate manually many times and measure the contact resistance if necessary.

d. Due to long-term moisture and suspension, please dry ATS before use. After removing dust and dirt, use a 500V megohmmeter to measure the insulation resistance between normal supply, alternating power supply, load side bar, including live parts and metal plate. And the insulation resistance should not be less than 10M.

8.4ATS shall be stored in an environment equivalent to the normal working environment, with dust-proof, moisture-proof and collision-proof measures.

9. Matters needing attention

9.1 Manual/Vautomatic operation

ATS can guarantee the performance of power generation and power failure during circuit operation, but for manual operation, ATS cannot guarantee the above performance due to the difference of power generation and power failure speed or operator. During manual power generation and power failure, excessive silver alloy loss may occur. Therefore, when all power supplies are cut off to check and maintain the operating system and contacts, it is only necessary to pull the selector switch to the manual position. Under normal circumstances, please pull the selector switch to the automatic position. When operating manually, pull the selector switch to the manual position. After the manual

operation is completed, pull the selector switch from the manual position to the automatic position.

9.2 Control circuit

ATS instantly becomes active. After the conversion is completed, the coil in the control circuit will be disconnected by the internal converter, Under the rated voltage of 80%-110%, the coil can operate normally Low voltage will cause coil heating and even spontaneous combustion.



CERTIFICATE

Product Model: YCQ4-100E/R PC type

Standard: IEC 60947-6-1

Inspector : **CNC003**

Production date: Printed on the product
or package.

This product is qualified according
to the delivery inspection

CNC

YCQ4-100E/R PC type

CNC ELECTRIC

Tel: 0086-577-61989999 Fax: 0086-577-61891122

www.cncele.com E-mail: cncele@cncele.com